

ProCOMP PARTS CATALOG – YOUR SOURCE
Telephone (888)388-4321 Fax (732)786-9511
www.ProCOMP-INC.com

TETW(SIZE) TEE THREAD X THREAD X THREAD

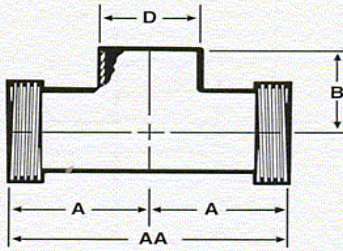

Size Tube OD	A	AA	B	D	Nom. Wall
1	1 13/16	3 5/8	1 1/8	1	.065
1 1/2	2 3/8	4 3/4	1 21/32	1 1/2	.065
2	2 25/32	5 9/16	2 1/16	2	.065
2 1/2	3 3/16	6 3/8	2 11/32	2 1/2	.065
3	3 1/2	7	2 19/32	3	.065
4	4 21/32	9 5/16	3 5/8	4	.083

X9WWWW(SIZE) CROSS

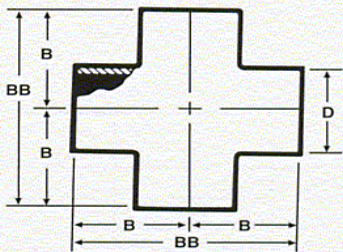

Size Tube OD	B	BB	D	Nom. Wall
1	1 1/8	2 1/4	1	.065
1 1/2	1 21/32	3 5/16	1 1/2	.065
2	2 1/16	4 1/8	2	.065
2 1/2	2 11/32	4 11/16	2 1/2	.065
3	2 19/32	5 3/16	3	.065
4	3 7/16	6 7/8	4	.083
6	5 5/8	11 1/4	6	.109

SE(SIZE)WA TYPE A STUB END WITH GROOVES

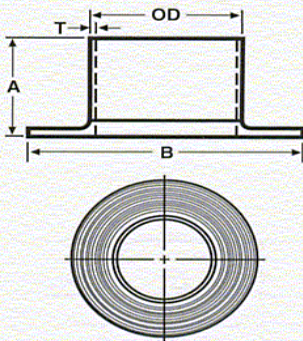

Size Tube OD	A	B	Nom. Wall (T)
1/2	1 3/8	1 5/8	.065
3/4	1 3/8	1 11/16	.065
1	1 5/8	2	.065
1 1/4	1 5/8	2 1/2	.065
1 1/2	1 3/4	2 7/8	.065
2	1 1/2	3 5/8	.065
2 1/2	2	4 1/8	.065
3	2 1/4	5	.065
4	2 5/8	6 3/16	.083
6	3	8 1/2	.109

CASW(SIZE) WELD CAP



Size Tube OD	A	Nom. Wall (T)
1	3/8	.065
1 1/4	1/2	.065
1 1/2	9/16	.065
2	3/4	.065
2 1/2	1	.065
3	1 1/4	.065
4	1 1/2	.083
6	2	.109

600 Park Ave., Manalapan, NJ 07726